

## Pressure gauges with glycerine filling

with stainless steel case  
according to EN 837-1/S2

Accuracy class 1.6

Nominal sizes ND 63

Licence:



**Germanischer Lloyd**



### Description

The time proven system technology of the glycerine pressure gauges has been integrated in a new stainless steel case with modern design. This instrument fulfills the safety requirements of EN 837-1/S2.

The glycerine filling of the case protects the measuring system against wear and tear by pulsating pressures and mechanical vibration; at the same time it provides lubrication of the moving parts.

The glycerine pressure gauges are suitable for gaseous and liquid media that do not corrode copper alloys.

The mounting bracket offers a possibility of quick modification for panel mounting with series P1453.

### Features

- o High dynamic load
- o Rugged construction
- o Complies EN 837-1/S2 standard
- o Protection IP 65 (EN 60 529/IEC 529)
- o Low wear
- o Versatile applications
- o Custom modification to panel mounting with bracket (model P1453)
- o Reducing of stock-holding costs
- o Low weight

### Measuring ranges

0 ... 1 bar to 0 ... 1000 bar

### Applications

Food industry, chemical industry; mining, shipyards, waste water technology, general machine construction, hydraulics, pumps, compressors, high pressure cleaning devices.

**Models: P1453, P1454**

## Technical data

Models	P1454	P1453	Options
Nominal size	63		
Symbol			
Accuracy class	1.6 to EN 837-1		
Ranges	0...1 bar to 0...1000 bar negative or positive or negative and positive gauge pressure		
Application	Constant load: 3/4 x full scale value Alternating load: 2/3 x full scale value		
Overpressure protection	full scale value		
Case	Stainless steel 1.4301 bright	Stainless steel 1.4301	polished
Bezel	Stainless steel 1.4301 bright	Stainless steel 1.4301 polished	triangular bezel, polished stainless steel
Mounting	none	with bracket	Front flange, stainless steel polished,
Window	Plexiglass		
Dial	Plastic white, scale and imprint black		AL white, Dual scale
Pointer	Plastic black		Brass black, AL black
Movement	CuZn-alloy		
Measuring element	Copper alloy up to 40 bar Bourdon tube; above 60 bar: helical tube; stainless steel 1.4571 $\geq$ 400 bar helical tube		
Thread	CuZn-alloy	back, central	Other threads on request
- position	above		1/4 NPT; G 1/8 B; M 12 x 1.5
- thread	G 1/4 B		
Liquid filling	Glycerine < 2.5 bar 86.5%, $\geq$ 2.5 bar 99.5%		
Temperatures			
- Medium	Tmin. -25°C, Tmax. 80°C		
- Ambient	Tmin. -25°C, Tmax. 60°C		
Temperature drift	0.3 %/10K if deviation from normal temperature 20°C		
Protection	IP 65 to EN 60 529/IEC 529		
Throttle	$\varnothing$ 0.3 ; $\varnothing$ 0.4 ; $\varnothing$ 0.8 Brass		
Weight approx.	0.21 kg	0.26 kg	

## Dimensions

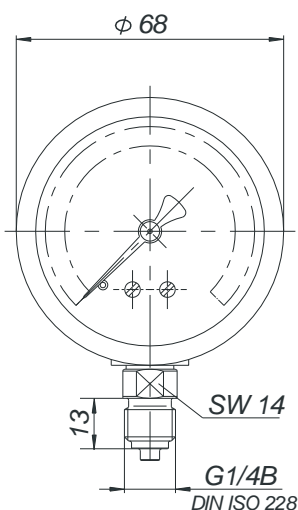

Model : P1454

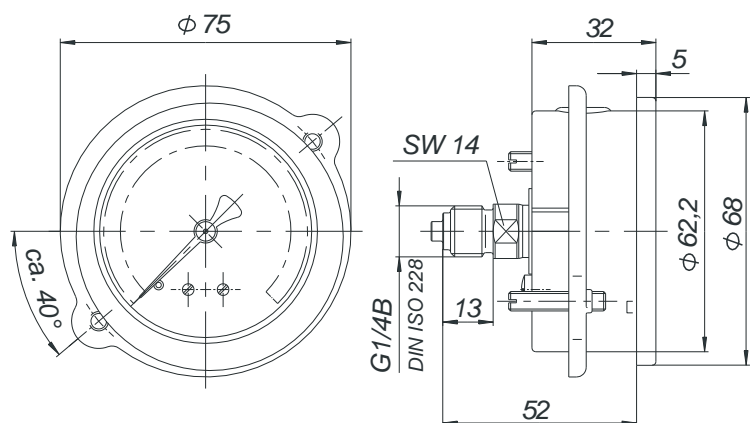

Model : P1453

Modifications reserved